



Supporting the Defense Industry by Protecting Digital Screens

Small Business Supplier

Custom screen protectors & privacy filters

Eight types of protective film (tough to anti-glare)

Three types of privacy filters – 4Way – 2Way & curved

Etching for military applications

Certified Lean Manufacturing

Laser cutter for precise cuts

Clean room for installation

Testing equipment (temperature & humidity)

Rapid response & quick turnaround

Kit manufacturing



Our materials:

- *Prevent injury
- *Save money
- *Protect privacy
- *Hinder glare

Member



One-on-One Consulting * Specializing in Custom Solutions * Multi-piece pricing * Free Samples



MISSION:

DETERMINED TO PROVIDE MILITARY DECISION-MAKERS WITH CUSTOM SCREEN PROTECTORS (SHOCK & SCRATCH RESISTANT AND/OR ANTI-GLARE) AND PRIVACY FILTERS OF ANY SHAPE AND SIZE.

RAPID RESPONSE OF PROTOTYPE & LOW TO HIGH-VOLUME PRODUCTION

DRIVEN TO PROVIDE SOLUTIONS FOR:

- DIGITAL SCREEN PROTECTION & SCREEN GLARE PROBLEMS
- SCREEN PRIVACY ISSUES
- CUSTOM CUT SCREEN PROTECTORS
- CUSTOM ETCHING FOR TRAINING & INVENTORY
- CUSTOM HELMET LINING PROTECTION/PADDING



OUR EXPERTISE:

- ONE-ON-ONE CONSULTING TO PROVIDE SOLUTIONS FOR PROTECTING ANY SHAPED DIGITAL EQUIPMENT SCREEN, UP TO 100 INCHES.
- EXPERTS IN PROVIDING AND SOURCING CLEAR AND ANTI-GLARE SCREEN PROTECTORS (BLUE LIGHT-CUT INCLUDED).
- OFFERING CUSTOM SOLUTIONS FOR TWO-WAY AND 4-WAY PRIVACY FILTER NEEDS.
- LASER ETCHING
- LAMINATING SERVICES
- SCREEN PROTECTOR INSTALLATION



PAST PERFORMANCE:



Census Bureau

Subcontracted on #GS-02F-0096R to provide anti-glare screen protectors for [Elite Book Tablets](#)



FBI

Photodon was awarded the prime contract on #DJF-16-011-P-0008722. We provided [custom cut privacy filters](#) for this contract.



US Airforce

Photodon custom cuts [3M adhesive backed microfiber cloths](#) used to protect pilots' helmet lenses from being scratched.



THE BOSTON CONSULTING GROUP



CASE STUDY #1:

The Challenge:

Knolls Atomic Power Laboratory (BMPC-KAPL) came to us with a request to make decals for computer screens for navy training exercises (see image).



Photodon's Solution:

Samples of MXO (clear) silicone backed films were sent. Once material was approved by BMPC-KAPL, Photodon made kiss-cut sets of shapes (using their artwork) and assigned a part for easy future ordering.

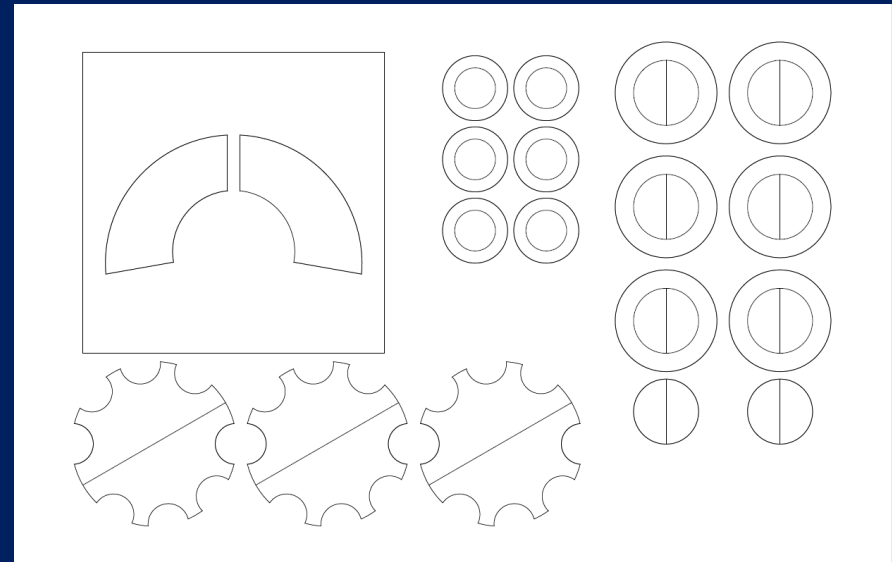



CASE STUDY #2:

The Challenge:

The FBI Quality Improvement Unit in Clarksburg, West Virginia needed to provide privacy for hundreds of their older monitors. They were unable to find privacy filters for their devices.



Photodon's Solution:

We worked with our contact at the FBI to get measurements of the various monitors. Paper templates were sent to ensure a proper fit prior to full production. Bulk discounted, perfectly fitted filters were sent within 3 weeks of the purchase order submission. Total number of filters: 450 (ranging from 24-30 inches).



Privacy filter for a curved monitor

Prime Contract #DJF-16-011-P-0008722



CASE STUDY #3:

The Challenge:

The US Census Bureau needed 7,000 anti-glare screen protectors for their HP EliteBook Revolves 810's for use in the 2020 census.

Photodon's Solution:

We were a subcontractor with EZ Print (Kentuckiana Copy Supply) and provided bulk priced, individually-packaged, anti-glare screen protectors with installation kits. Our shipping manager worked with the shipping company to ensure safe delivery (they were shipped on a pallet). They arrived safely & on time.

